

www.newmaker.com

中华人民共和国国家标准

UDC 621.961.02

冷冲模复合模典型组合
圆形薄凹模典型组合

GB 2873.4—81

Typical assembly of compound die for cold press dies
Typical assembly with round thin die plate

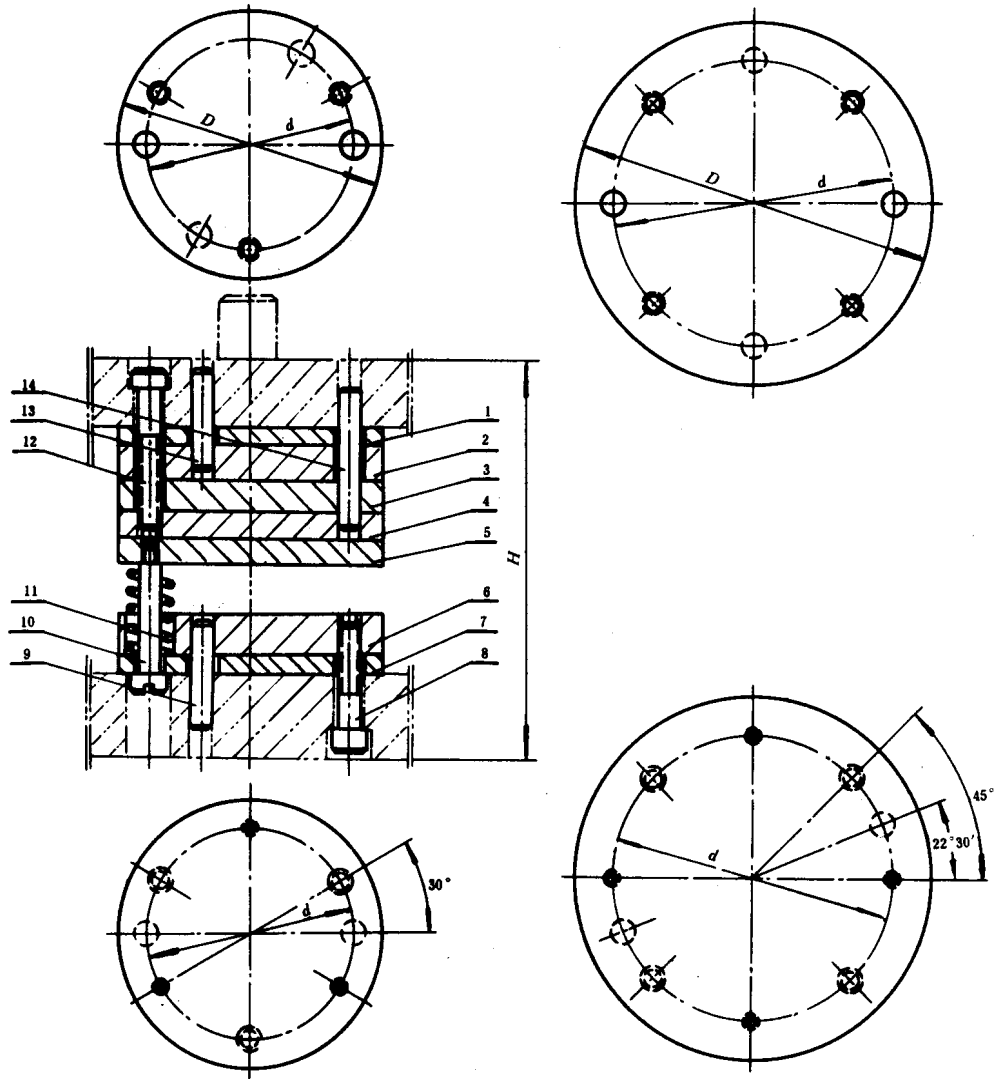

标记示例:

凹模周界 $D = 125 \text{ mm}$ 、配用模架闭合高度 H 为 $140 \sim 170 \text{ mm}$ 的圆形薄凹模典型组合:
典型组合 $125 \times 140 \sim 170$ GB 2873.4—81

www.newmaker.com

凹模周界		D										
凸凹模长度		63	80	100	125	(140)	160	200	250	(280)	315	
配件模架闭合高度 H		32	40	40	44	52	54	61	66	68		
孔距尺寸 d		110	130	130	140	160	180	200	220	245		
最 小		125	150	150	170	190	220	240	260	280		
最 大		47	56	76	95	110	124	164	214	279		
零件件号、名称及标准编号		规格										
1	垫板 GB 2858.6-81	63 × 4	80 × 4	100 × 4	125 × 6	(140) × 6	160 × 8	200 × 8	250 × 10	(280) × 10	315 × 10	
2	固定板 GB 2858.5-81	63 × 10	80 × 12	100 × 12	125 × 14	(140) × 16	160 × 18	200 × 20	250 × 22	(280) × 25	315 × 25	
3	空心垫板 GB 2858.5-81	63 × 8	80 × 10	100 × 10	125 × 12	(140) × 14	160 × 16	200 × 18	250 × 20	(280) × 20	315 × 20	
4	凹模 GB 2858.4-81	63 × 10	80 × 12	100 × 12	125 × 14	(140) × 14	160 × 16	200 × 18	250 × 20	(280) × 20	315 × 20	
5	卸料板 GB 2858.5-81	63 × 6	80 × 8	100 × 8	125 × 10	(140) × 12	160 × 14	200 × 16	250 × 18	(280) × 20	315 × 20	
6	固定板 GB 2858.5-81	63 × 12	80 × 14	100 × 14	125 × 16	(140) × 18	160 × 20	200 × 22	250 × 25	(280) × 28	315 × 28	
7	垫板 GB 2858.6-81	63 × 4	80 × 4	100 × 4	125 × 6	(140) × 6	160 × 8	200 × 8	250 × 10	(280) × 10	315 × 10	
8	螺钉 GB 70-76	M5 × 30	M8 × 35	M10 × 45	M10 × 50	M12 × 60	M12 × 65	M12 × 75	M12 × 80	M12 × 90	M12 × 100	
9	圆柱销 GB 119-76	5 × 30	8 × 30	10 × 45	10 × 50	12 × 60	12 × 75	12 × 80	12 × 80	12 × 90	12 × 100	
10	卸料螺钉 GB 2867.5-81	5 × 32	8 × 38	10 × 42	10 × 48	12 × 50	12 × 55	12 × 60	12 × 60	12 × 60	12 × 60	
11	弹簧 GB 2089-80	设计选用。亦可用橡皮，聚胺酯，碟形弹簧										
12	螺钉 GB 70-76	M5 × 45	M8 × 50	M10 × 60	M10 × 70	M12 × 80	M12 × 90	M12 × 95	M12 × 100	M12 × 100	M12 × 100	
13	圆柱销 GB 119-76	5 × 30	8 × 30	10 × 35	10 × 40	12 × 50	12 × 50	12 × 60	12 × 60	12 × 60	12 × 60	
14	圆柱销 GB 119-76	5 × 45	8 × 50	10 × 60	10 × 70	12 × 80	12 × 80	12 × 90	12 × 90	12 × 90	12 × 90	

注：括号内的尺寸尽可能不采用。
技术条件：按GB 2875-81的规定。