

www.newmaker.com

中华人民共和国国家标准

UDC 621.961.02

冷冲模卸料装置 圆柱头卸料螺钉

GB 2867.5—81

Stripping set of cold press dies
Cylindrical head stripper bolt

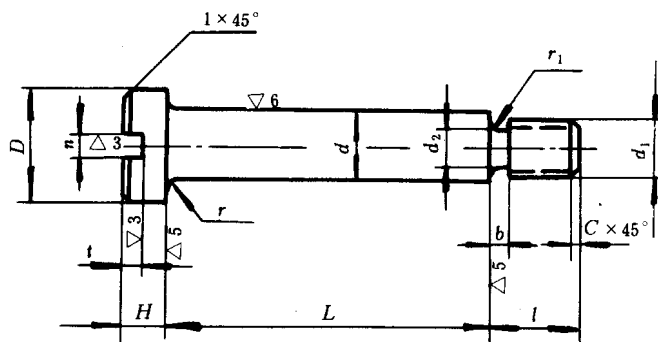

其余∇4

标记示例:

直径 $d = 10\text{ mm}$ 、长度 $L = 48\text{ mm}$ 的圆柱头卸料螺钉:

卸料螺钉 10 × 48 GB 2867.5—81

mm

d	L (h8)		d ₁	l	D	H	n	t	r <	r ₁ <	d ₂	b	C
	基本尺寸	极限偏差											
4	20	0 -0.033	M 3	5	7	3	1	1.4	0.2	0.3	2.2	1	0.6
	22												
	25												
	28												
	30												
	32												
5	35	0 -0.039	M 4	5.5	8.5	3.5	1.2	1.7	0.4	0.5	3	1.5	0.8
	20												
	22												
	25												
	28												
	30												
	32												
	38												
40													

续表

mm

d	L(h8)		d ₁	l	D	H	n	t	r<	r ₁ <	d ₂	b	C
	基本尺寸	极限偏差											
6	25	0 -0.033	M 5	6	10	4	1.5	2			4	1.5	1
	28												
	30												
	32	0 -0.039											
	35												
	38												
	40												
	42												
	45												
	48												
50													
8	25	0 -0.033	M 6	7	12.5	5	2	2.5	0.4		4.5		1.2
	28												
	30												
	32	0 -0.039											
	35												
	38												
	40												
	42												
	45												
	48												
	50												
	55	0 -0.046											
	60												
	65												
70													
10	30	0 -0.033	M 8	8	15	6	2.5	3	0.5		6.2	2	1.5
	32	0 -0.039											
	35												
	38												
	40												
	42												
	45												
	48												
50													

续表

mm

d	L(h8)		d ₁	l	D	H	n	t	r<	r ₁ <	d ₂	b	C
	基本尺寸	极限偏差											
10	55	0 -0.046	M 8	8	15	6	2.5	3	0.5	0.5	6.2	2	1.5
	60												
	65												
	70												
	75												
	80												
12	35	0 -0.039	M10	10	18	7					7.8	2	
	40												
	45												
	50												
	55	0 -0.046											
	60												
	65												
	70												
	75												
	80												
16	40	0 -0.039	M12	14	24	9	3	3.5		1	9.5	3	2
	45												
	50												
	55	0 -0.046											
	60												
	65												
	70												
	75												
	80												
	90	0 -0.054											
	100												

材料：45号钢 GB 699-65。

热处理：硬度HRC 35~40。

技术条件：按GB 89-76的规定《螺钉技术条件》。