

www.newmaker.com

中华人民共和国国家标准

UDC 621.961.02

冷冲模凸、凹模 圆凹模

GB 2863.4-81

Punches and dies of cold press dies  
Round die button

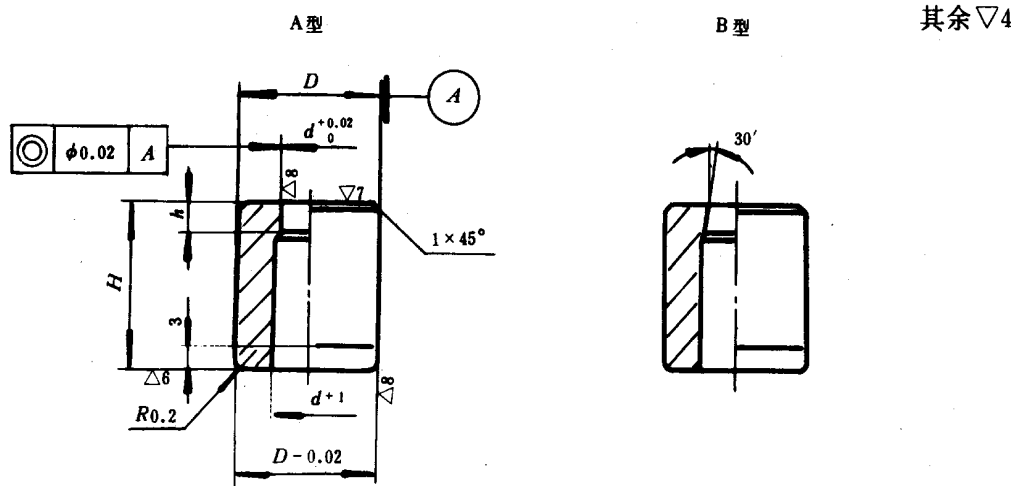

标记示例:

孔径  $d = 8.6\text{mm}$ 、刃壁高度  $h = 4\text{mm}$ 、高度  $H = 22\text{mm}$ 、材料为 T10A 的 A 型圆凹模:

凹模 A8.6 × 4 × 22 GB 2863.4-81 · T10A

mm

d	D(m6)		h	H								
	基本尺寸	极限偏差		14	16	18	20	22	25	28	30	35
料厚 < 2	8	+0.015 +0.006	3									
			5									
2-4	12	+0.018 +0.007	3									
			5									
4-6	14	+0.018 +0.007	3									
			5									
6-8	16	+0.018 +0.007	4									
			6									
8-10	20	+0.021 +0.008	4									
			6									

续表

mm

d	D(m6)		h	H									
	料厚 < 2	基本尺寸		极限偏差	14	16	18	20	22	25	28	30	35
10-12	22	+0.021 +0.008	6										
			8										
12-15	25		6										
			8										
15-18	30	+0.025 +0.009	8										
			10										
18-22	35		8										
			10										
22-28	40		8										
			10										

材料: T10A GB 1298-77。

9Mn2V GB 1299-77。

Cr6WV GB 1299-77。

Cr12 GB 1299-77。

热处理: 硬度HRC58~62。

技术条件: 按GB 2870-81的规定。