

www.newmaker.com

中华人民共和国国家标准

UDC 621.961.02

冷冲模模柄 压入式模柄

GB 2862.1—81

Shank of cold press dies
Shank of press fit

其余▽4

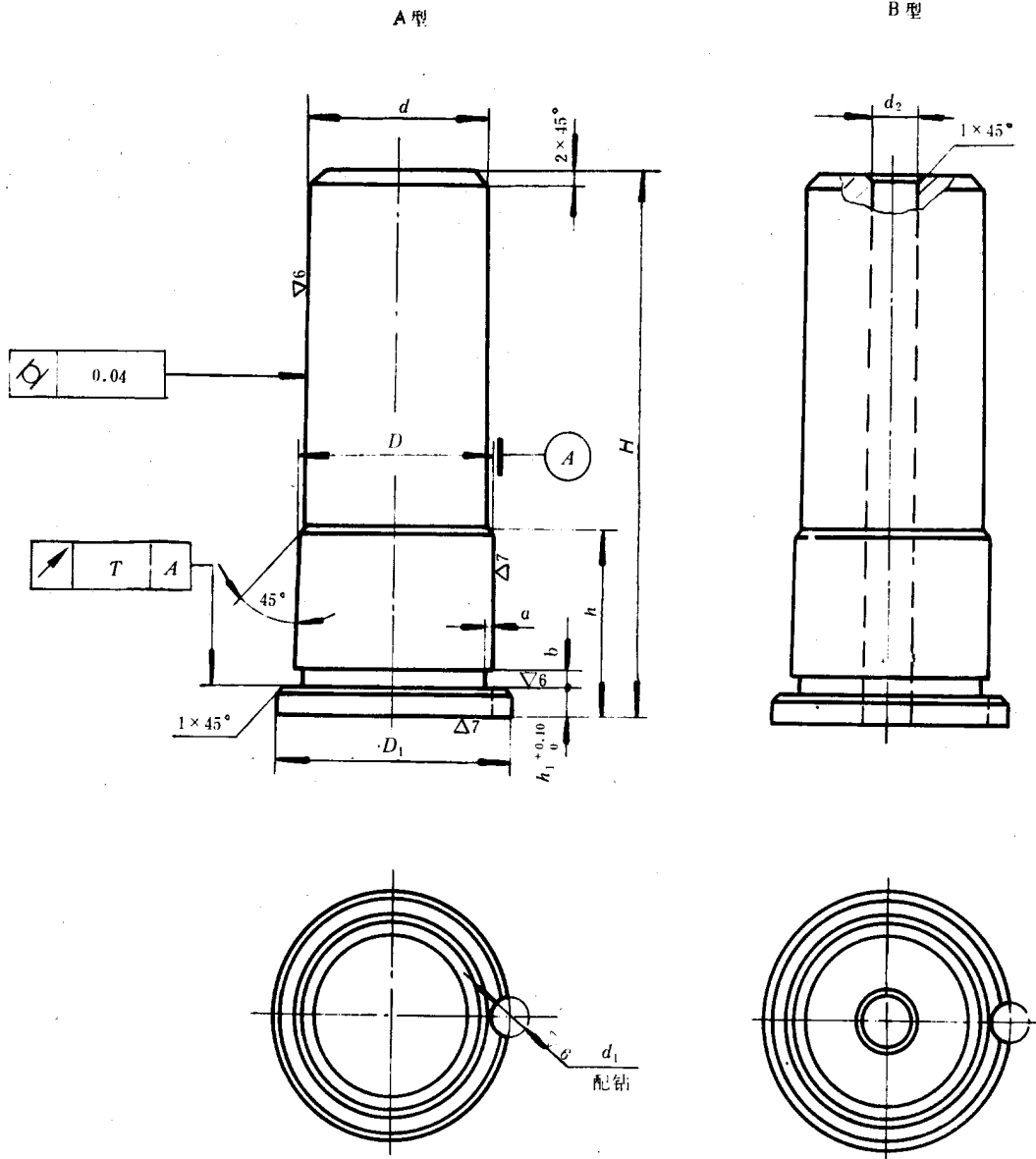

标记示例:

直径 $d = 30 \text{ mm}$ 、高度 $H = 73 \text{ mm}$ 、材料为 A3 的 A 型压入式模柄:

模柄 A30 × 73 GB 2862.1—81 · A3

GB 2862.1-81

mm

d(d11)		D(m6)		D ₁	H	h	h ₁	b	a	d ₁ (H7)		d ₂							
基本尺寸	极限偏差	基本尺寸	极限偏差							基本尺寸	极限偏差								
20	-0.065 -0.195	22	+0.021 +0.008	29	68	20	4	2	0.5	6	+0.012 0	7							
					73	25													
					78	30													
25		26		33	68	20													
					73	25													
					78	30													
30		32		39	39	83							35	5	3	1	6	+0.012 0	11
						88							40						
						73							25						
						78							30						
32	34	42	42	83	35	5	3	1	6	+0.012 0	11								
				88	40														
				73	25														
				78	30														
35	38	38	+0.025 +0.009	46	85	25	6	3	1	6	+0.012 0	13							
					90	30													
					95	35													
					100	40													
					105	45													
38	-0.080 -0.240	40	48	48	90	30	6	3	1	6	+0.012 0	13							
					95	35													
					100	40													
					105	45													
					110	50													
40	42	42	50	50	90	30	6	3	1	6	+0.012 0	13							
					95	35													
					100	40													
					105	45													
					110	50													
50	52	+0.030 +0.011	61	61	95	35	8	3	1	6	+0.015 0	17							
					100	40													
					105	45													
					110	50													
					115	55													
					120	60													

GB 2862.1-81

续表

mm

d (d11)		D(m6)		D ₁	H	h	h ₁	b	a	d ₁ (H7)		d ₂
基本尺寸	极限偏差	基本尺寸	极限偏差							基本尺寸	极限偏差	
60		62		71	110	40	8			8		17
					115	45						
					120	50						
					125	55						
					130	60						
					135	65						
					140	70						
76	-0.100 -0.290	78	+0.030 +0.011	89	123	45	10	4	1	10	+0.015 0	21
					128	50						
					133	55						
					138	60						
					143	65						
					148	70						
					153	75						
					158	80						

材料: A3、A5 GB 700-79。
 技术条件: 按GB 2870-81的规定。