

www.newmaker.com

中华人民共和国国家标准

UDC 621.961.02

冷冲模模板 矩形凹模板

GB 2858.1-81

Plates for cold press dies  
Rectangular die plate

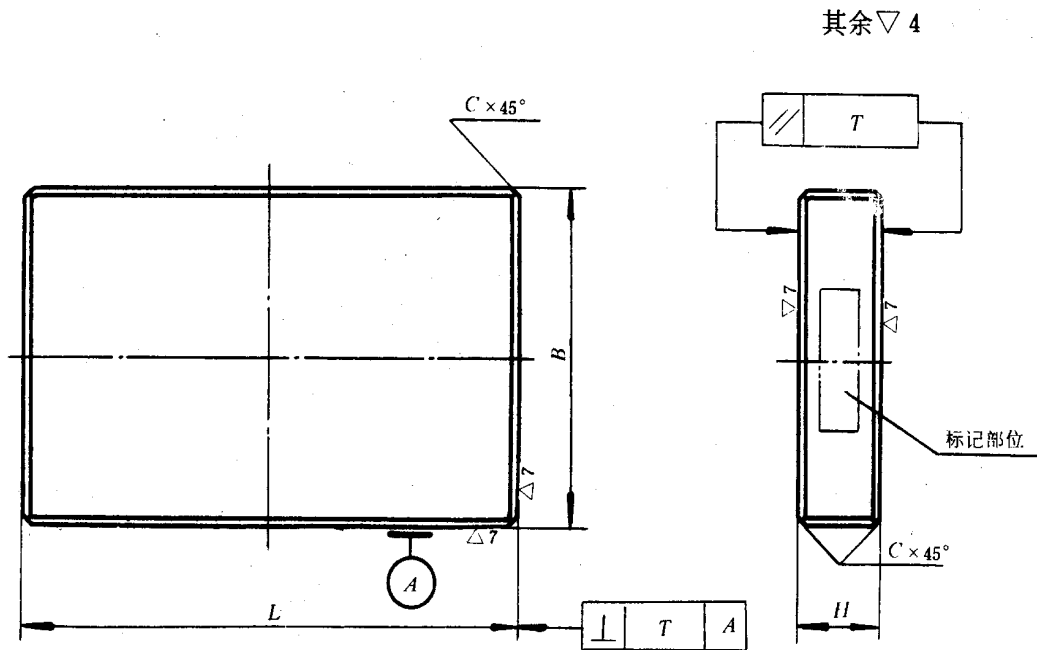

标记示例:

长度  $L = 125\text{mm}$ 、宽度  $B = 100\text{mm}$ 、厚度  $H = 20\text{mm}$ 、材料为 T 10 A 的矩形凹模板:

凹模板 125×100×20 GB 2858.1-81·T10A

mm											
$L$	$B$	$H$	$C$	$L$	$B$	$H$	$C$	$L$	$B$	$H$	$C$
63	50	10	1	80	63	12	1	80	80	12	1
		12				14				14	
		14				16				16	
		16				18				18	
		18				20				20	
		20				22				22	
63	63	10	1	100	63	12	1	100	80	12	1
		12				14				14	
		14				16				16	
		16				18				18	
		18				20				20	
		20				22				22	

续表

mm

L	B	H	C	L	B	H	C	L	B	H	C
125	80	12	1	125	125	14	1.5	200	(140)	16	1.5
		14				20					
		16				22					
		18				25					
		20				28					
		22				32					
(140)	80	14	1	(140)	125	14	1.5	250	(140)	16	1.5
		16				20					
		18				22					
		20				25					
		22				28					
		25				32					
100	100	12	1	160	125	14	1.5	160	160	16	1.5
		14				20					
		16				22					
		18				25					
		20				28					
		22				32					
125	100	14	1	200	125	14	1.5	200	160	16	1.5
		16				20					
		18				22					
		20				25					
		22				28					
		25				32					
(140)	100	14	1	250	125	16	1.5	250	160	18	1.5
		16				20					
		18				22					
		20				25					
		22				28					
		25				32					
160	100	16	1	(140)	125	14	1.5	(280)	160	18	1.5
		18				20					
		20				22					
		22				25					
		25				28					
		28				32					
200	100	16	1	160	125	14	1.5	200	200	18	1.5
		18				20					
		20				22					
		22				25					
		25				28					
		28				32					

GB 2858.1-81

续表

mm

L	B	H	C	L	B	H	C	L	B	H	C
250	200	18	1.5	315	200	20	1.5	(280)	250	20	2
		22				25				25	
		25				28				28	
		28				32				32	
		32				35				35	
		35				40				40	
(280)	200	20	1.5	250	250	20	2	315	250	20	2
		25				25				28	
		28				28				32	
		32				32				35	
		35				35				40	
		40				40				45	

注：括号内的尺寸尽可能不采用。

材料：T10A GB 1298-77 《碳素工具钢技术条件》

Cr12、Cr6WV、9Mn2V、Cr12MoV GB 1299-77 《合金工具钢技术条件》。

热处理：硬度设计自定。

技术条件：按GB 2870-81的规定。