

www.newmaker.com

中华人民共和国国家标准

UDC 621.961.02

冷冲模通用模座 带柄矩形上模座

GB 2857.2-81

Universal holder for cold press dies
Rectangular punch holder with shank

其余▽4

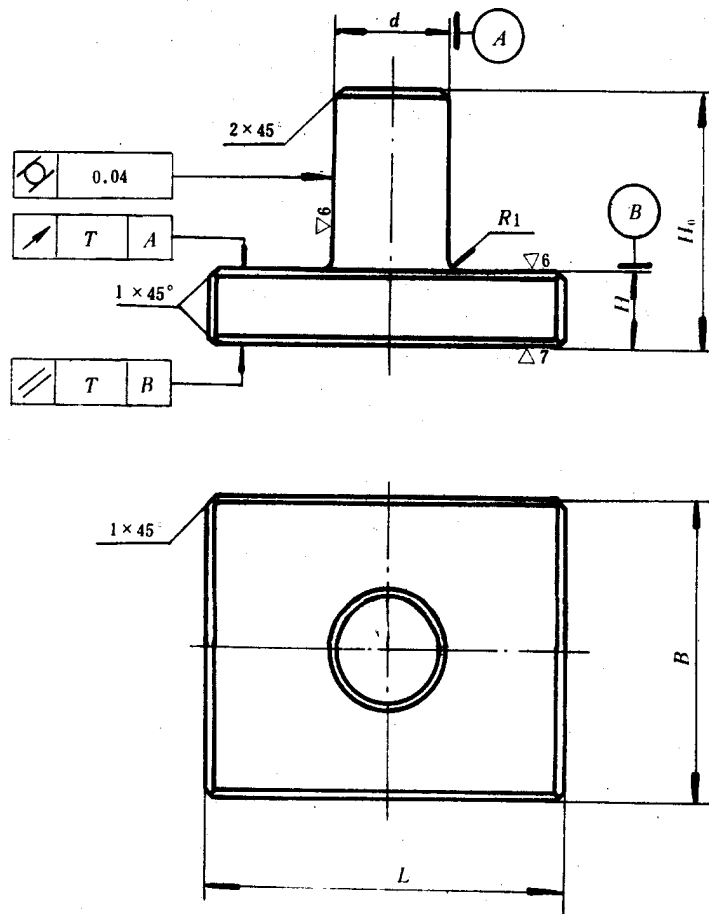

标记示例:

长度 $L = 125$ mm、宽度 $B = 100$ mm、厚度 $H = 25$ mm、

材料为A3的带柄矩形上模座:

上模座 125×100×25 GB 2857.2-81·A3

GB 2857.2-81

mm

d (d11)		L	B	H ₀	H	d (d11)		L	B	H ₀	H
基本尺寸	极限偏差					基本尺寸	极限偏差				
25		63	50	64	16	32		125	100	73	25
				78	30			(140)			
			64	16	160						
			78	30	200						
			64	16	100						
			78	30	(140)						
		80	63	64	16	38		100	80		
				78	30			(140)			
				64	16			100			
				78	30			125			
				68	20			(140)			
				83	35			160			
30	-0.065 -0.195	100	80	68	20	40	200	100	85	25	
				83	35		100				
				68	20		125				
				83	35		(140)				
				68	20		160				
				83	35		200				
		125	80	68	20	50	100	80			
				83	35		(140)				
				68	20		125				
				83	35		(140)				
				68	20		160				
				83	35		200				
32	-0.080 -0.240	80	80	68	20	50	250	125	87	27	
				83	35		(140)				
				68	20		160				
				83	35		200				
				68	20		250				
				83	35		(140)				
		(140)	80	68	20	160	160	160			
				83	35		200				
				68	20		250				
				83	35		160				
				68	20		200				
				83	35		160				
100	100	73	25	200	200	90					
		73	25		30						

注：括号内的尺寸尽可能不采用。

材料：A3、A5 GB 700-79。

技术条件：按GB 2870-81的规定。