

卡套式焊接接头体

Weld male connector—Body

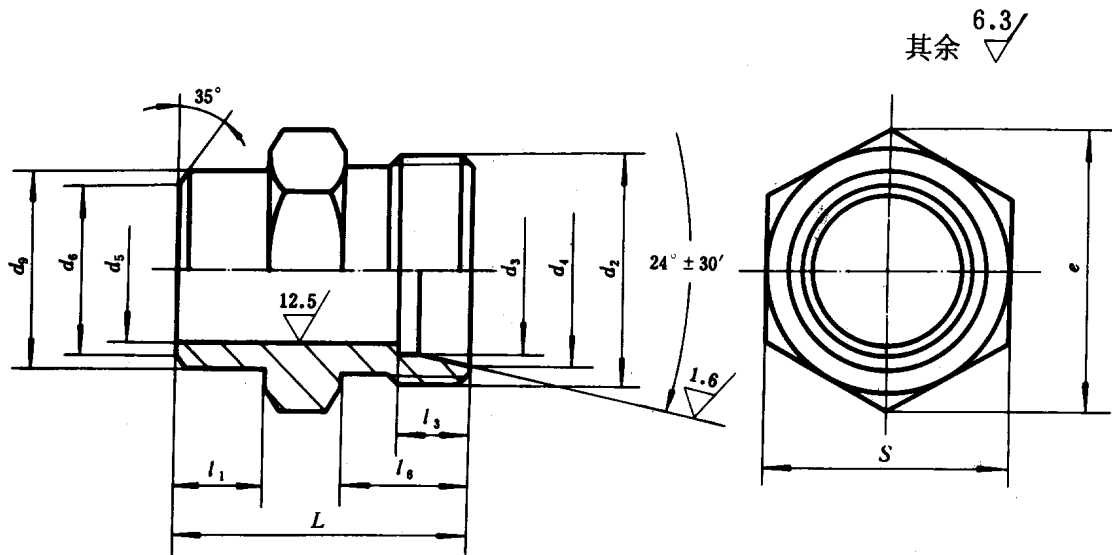

标记示例:

公称压力J级, 管子外径 D_0 为14mm的卡套式焊接接头体:

接头体 J14 GB 3747.2—83

mm

公称压力 (巴)	管子 外径 D_0	d_2	d_3	d_4	d_5		d_6		d_7	l_1	l_2	l_3		L	s	e	重量 (kg/100件)
					公称 尺寸	极限 偏差	公称 尺寸	极限 偏差				公称 尺寸	极限 偏差				
G (250)	4	M10×1	8	3	4	+0.28 +0.21	6.1	+0.10 0	5	7	8.5	6.5	21.5	13	15		1.51
	5			3.5	5		7.1										
	6	M12×1.25	10	4	6		8.1		7	10.7	7	23.7			1.88		
	8	M14×1.5	11	6	8		10.1		8	13		28	15	17.3	2.87		
	10	M16×1.5	13	8	10		12.3		11	8	13.5	28.5	18	20.8	3.88		
	12	M18×1.5	15	10	12		14.3		12							29.5	21
	14	M20×1.5	17	12	14		16.3		13		31.5			5.79			
	16	M22×1.5	19	14	16		18.3		15	10	7.5	32.5	24	27.7	7.30		
	18	M24×1.5	21	15	18		20.3		17							32.5	27
	20	M27×1.5	24	17	20		22.7		20		8.5	35.5	30	34.6	12.4		
	22	M30×2	26	19	22		24.7		22	12	18	9.5	40	34	39.3	14.3	
	25	M33×2	30	22	25		27.7		24								42
	28	M36×2	32	24	28		30.7		27	13	19	10.5	44	41	47.3	23.8	
	32	M42×2	38	27	32		35		33	14							47
34	M45×2	42	30	34	37	37	15	49			42.8						
40	M48×2	44	34	40	43	38	16	50	50	57.7	46.4						
42	M52×2	48	36	42	45	42	17	51	55	63.5	52.5						
J (400)	6	M14×1.5	12	3	6	+0.28 +0.21	8.1	+0.40 +0.30	6	7	13.5	7	27.5	15	17.3		2.47
	8	M16×1.5	14	5	8		10.1										
	10	M18×1.5	16	7	10		12.3		10	9	7.5	31.5	21	24.2	6.39		
	12	M20×1.5	17	8	12		14.3		12							32.5	
	14	M22×1.5	19	10	14		16.3		14	10	14	8	34	24	27.7	9.75	
	16	M24×1.5	21	12	16		18.3		16								35
	18	M27×1.5	24	14	18		20.3		18	12	19	9	38	30	34.6	13.4	
	20	M30×2	26	16	20		22.7		20								42
	22	M33×2	30	18	22		24.7		23		45			22.9			
	25	M36×2	32	20	25		27.7		25	13	20	11.5	47	41	47.3	30.1	
28	M39×2	36	22	28	30.7	28		48									33.5

注：重量系计算值，比重为7.85 kg/dm³。

技术条件按GB 3765—83的规定。

附加说明：

本标准由中华人民共和国机械工业部提出，由机械工业部标准化研究所归口。

本标准由机械工业部标准化研究所负责起草，由沈阳重型机器厂、重庆重型汽车研究所、大连组合机床研究所、浙江省海盐县管件厂、上海市机电一局科技情报所、航天部七〇八所等参加起草。

本标准主要起草人胡鲁生、刘德全、程振世、王慕秦。

自本标准实施之日起，原部标准JB 1971—77《卡套式焊接接头体》作废。